



The mobile multi-purpose parts washer is a perfectly ergonomic and heating device that runs with low pressure.

Combined with the cleaning solution, it perfectly cleans brake systems or mechanical parts without any solvent, dust or fiber projections.



Reinigingsoplossing:
ECOWAVE LIQUID



Tabletten met micro-organismen:
ECOWAVE TABLETS

Technical Features

Parts washer dimensions	820 x 530 x 1050 mm
Cleaning table dimensions	550 x 430 x 150 mm
Empty weight	23 kg
Tank volume	40 liters
Soaking tray	4 liters / useable dimensions of the tray: 240 x 220 x 80 mm
Pump flow	adjustable from 0 to 6 litres/min + low flow tap
Heating power	2 KW
Average electrical consumption	150 W/H
Maximum load	30 kg
Mobility	4 wheels polyurethane, 1 with brake
Component	HDPE
Tools	Interchangeable brush, soufflette tête plate
Filtration	Bag filter polypropylene 50 µm
Electrical supply	230 V ≈

Sketch

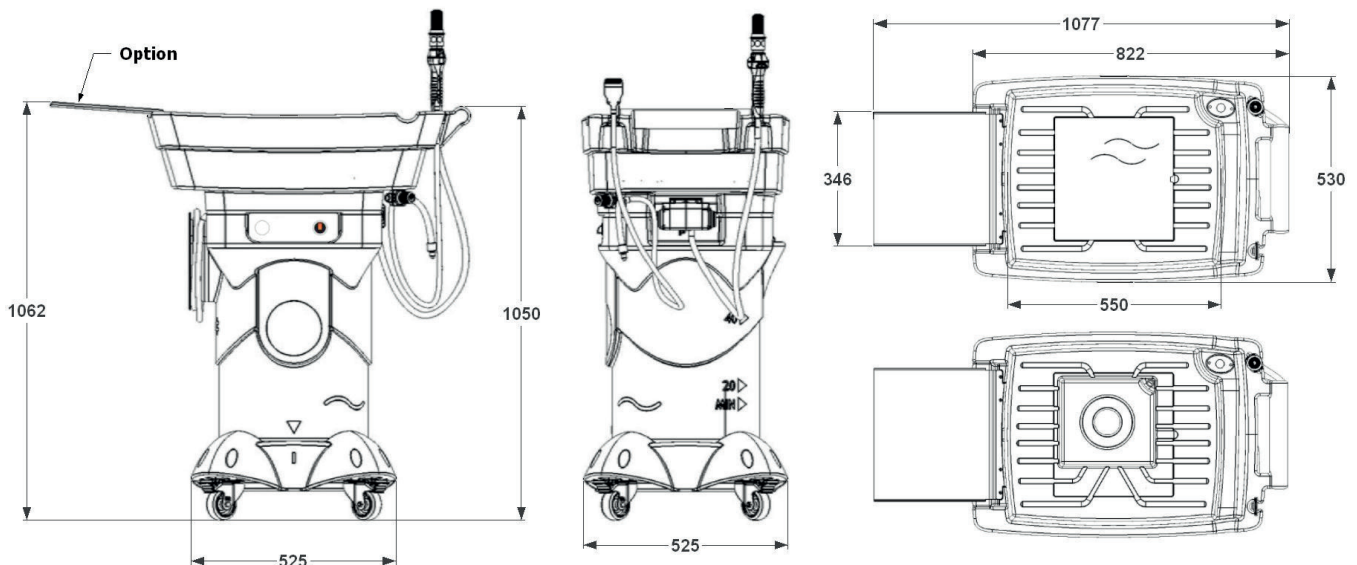

Technical Description



MOBILE MACHINE

Fountain with 4 wheels
functioning when hot



HEATING SYSTEM

Heating time from 15 to
38°C in 15 min



EASY MAINTENANCE

Electromechanical box
interchangeable without
tools



ERGONOMIC CLEANING TABLE

Protection of cleaning tools



DIP-COATING ZONE

Allows you to work as a back-
ground task

3D views



Ergonomic cleaning
table



Electromechanical box can
be dismantled without tools

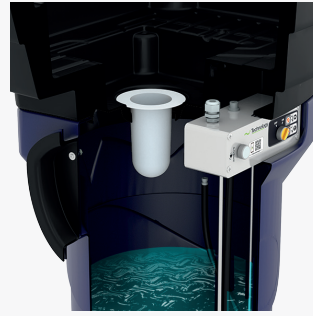

Filter socks 50µm

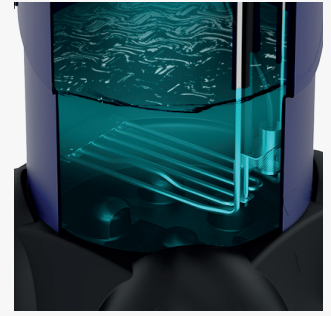

Heating time from 15 to
38°C in 15 min